

The Triple Reduction Worm/Worm/Worm Flexaline Speed Reducer

New dimension and assembly drawings, and rating tables plus more in the Worm/Worm/Worm section...

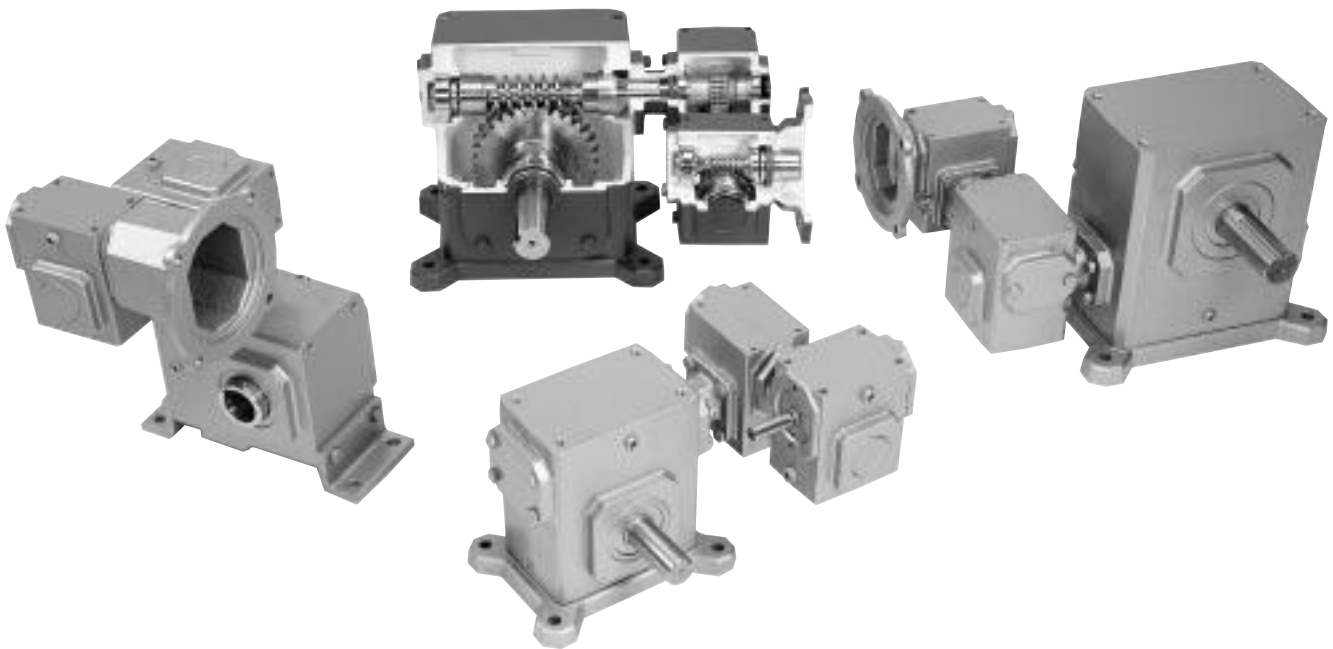

Triple Reduction

Worm / Worm / Worm Reduction Product Features

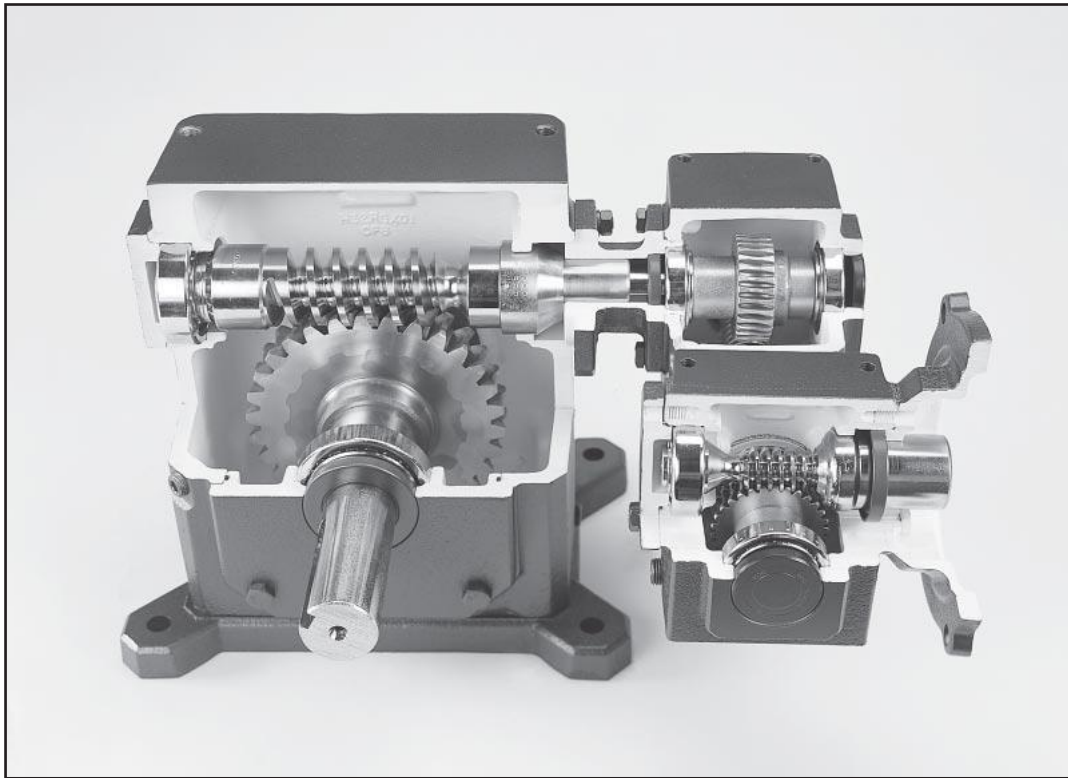

- **Rugged iron housings**, covers, and flanges, provide superior strength and rigidity.
- **Single cover output design** ensures gear centering for maximum efficiency and minimum noise levels.*
- **Three separate housings** in the triple reduction design insures long trouble free life of all components.
- The **worm shaft** is cut integral with the input shaft then hardened, ground, and polished to provide maximum efficiency with minimum gear noise.
- The **bronze worm gear** is chill cast from the highest quality bronze to provide superior wear and lubricity characteristics for longer life and higher efficiency.
- **Premium tapered roller bearings** on output shafts provide greater life, overhung load and thrust capacity.
- **Oversized steel output shafts** provide superior overhung load and torque characteristics.
- **Premium Chicago Rawhide Viton® double lip seals** provide extended life because of increased resistance to high temperature, abrasion and chemicals.*
- **O-rings on input and output covers** provide positive sealing without undependable gaskets or messy silicone sealants.*
- **Non-compressible metal shims** maintain factory bearing settings and gear alignment throughout the life of the product.*
- The unique **quill seal guard** protects the input seal from damage during motor installation.*
- **Large oil capacity** provides positive splash lubrication and superior cooling capability.
- **Metal nameplate drive screwed to housing** insures easy field identification for repair parts and replacement.
- **Units are oil filled at the factory** with the proper lubrication to provide simple and economical installation.**
- **All units are 100% run and leak tested** at the factory to insure that you receive the highest quality product.

*Standard on unit sizes up to and including 5 1/4 inch center distance only. (Size 213 to 252)

**Seven, eight, and ten inch center distance reducers are shipped without oil. (Sizes 2700, 2800 and 21000)

Triple Reduction

Worm / Worm / Worm Selection Guide

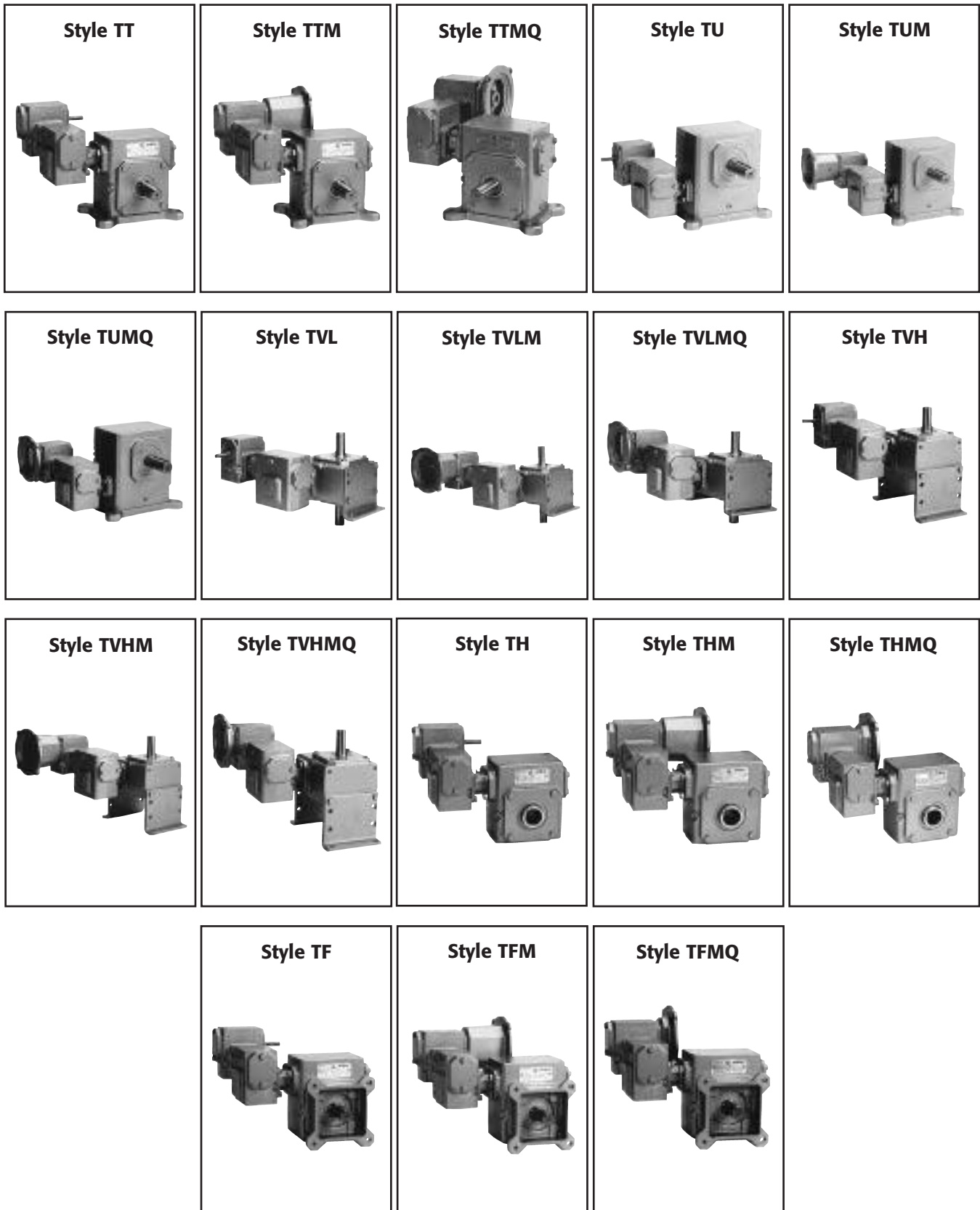

GROVE GEAR