

Double Reduction

Worm / Worm Dimensions

Style DF

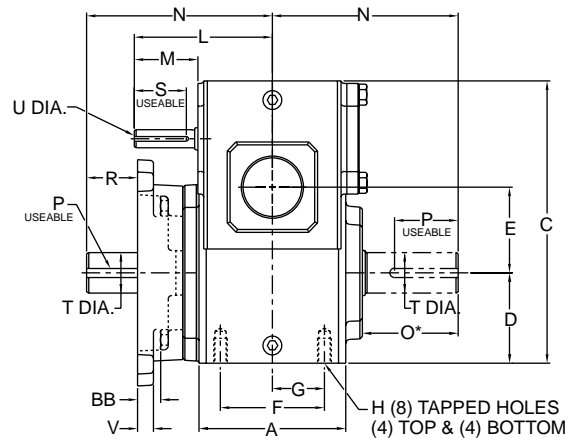
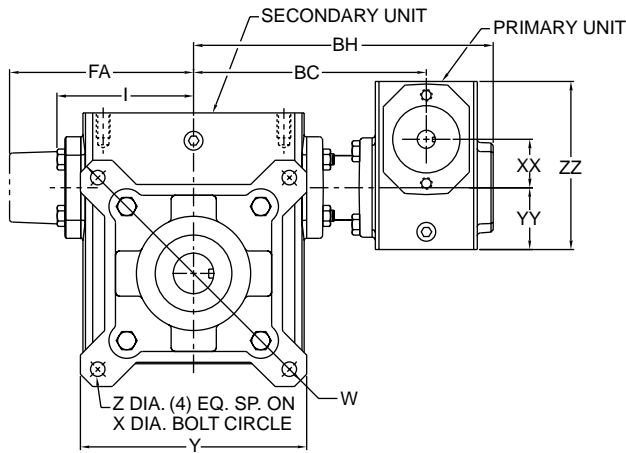

Styles DFM & DFMQ

STYLE DFMQ
(NEMA AND IEC B5 METRIC MOTORS)

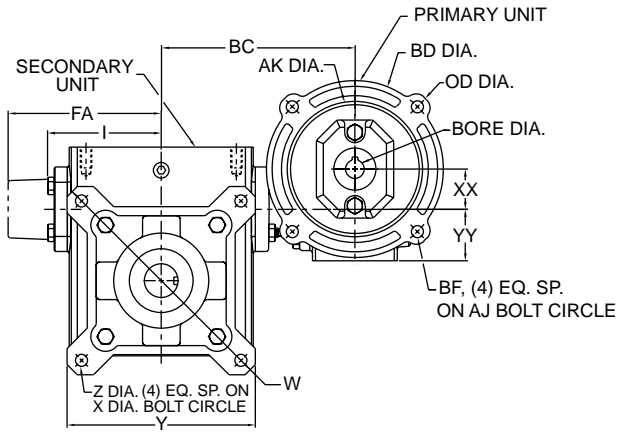

STYLE DFM
(NEMA MOTORS ONLY)

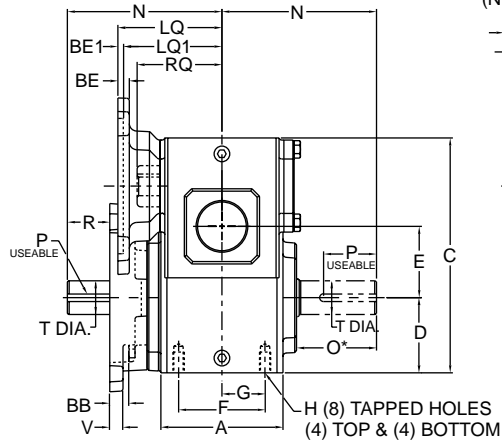

Assemblies

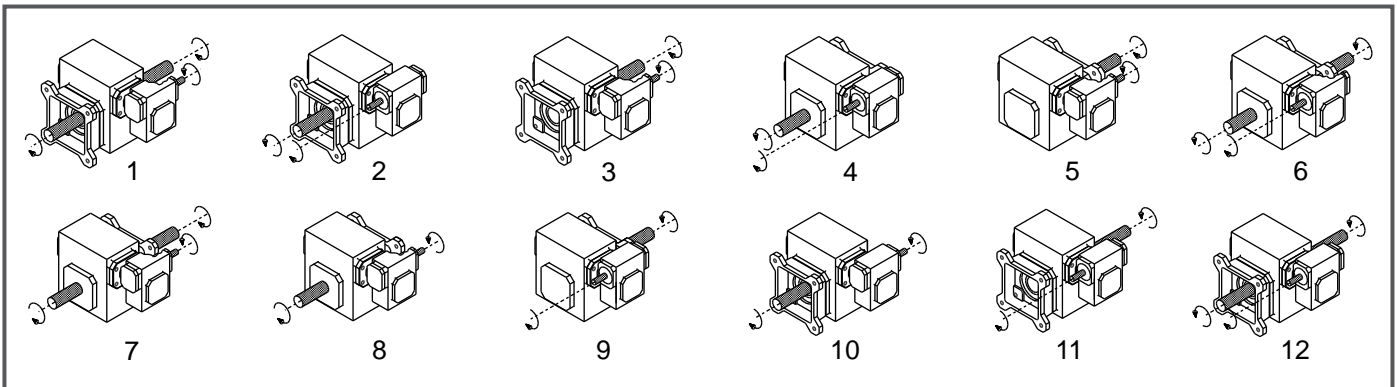

Note: The input shaft may be rotated in either direction. Units are for mounting as shown. Contact factory for other mountings. Assembly positions also apply to motor flange units ("MQ" and "M").



Double Reduction

Styles DF, DFMQ, DFM

UNIT	A	BB	BC	BH	C	D	E	F	FA	G	H	H Depth	I	L	M	N	O*	P**	R	S**
213	2.82	.08	5.32	7.16	5.99	1.72	1.333	2.00	N/A	1.00	5/16-18	.50	2.61	3.82	1.76	4.00	2.16	3/16 x 1.50	1.48	1/8 x 1.44
215	3.44	1.22	5.85	7.69	6.38	1.91	1.540	2.75	N/A	1.38	5/16-18	.63	3.14	3.82	1.76	4.31	2.11	3/16 x 1.50	1.44	1/8 x 1.44
218	3.56	.11	5.94	7.79	6.75	2.06	1.750	2.75	N/A	1.38	5/16-18	.63	3.24	3.82	1.76	4.31	2.05	3/16 x 1.38	1.13	1/8 x 1.44
220	3.81	.55	6.32	8.16	7.28	2.28	2.063	3.00	N/A	1.50	5/16-18	.63	3.61	3.82	1.76	4.68	2.29	1/4 x 1.44	.99	1/8 x 1.44
224	4.06	.51	6.44	8.29	7.81	2.50	2.375	2.88	N/A	1.44	3/8-16	.69	3.77	3.82	1.76	5.14	2.66	1/4 x 1.75	1.47	1/8 x 1.44
226	4.84	.04	7.01	8.85	8.50	2.94	2.625	3.38	N/A	1.69	3/8-16	.69	4.34	3.82	1.76	5.63	2.73	1/4 x 2.00	1.99	1/8 x 1.44
230	5.25	.07	7.86	10.06	9.72	3.25	3.000	4.00	N/A	2.00	7/16-14	.88	4.84	4.35	1.76	6.75	3.60	1/4 X 2.25	3.03	3/16 x 1.50
232	5.75	.07	8.05	10.25	10.22	3.50	3.250	4.00	N/A	2.00	7/16-14	.88	5.02	4.35	1.76	7.06	3.66	3/8 X 2.62	3.08	3/16 x 1.50
242	6.13	.06	9.18	11.57	12.78	4.44	4.250	5.00	N/A	2.50	5/8-11	1.00	6.10	4.82	1.76	8.12	4.50	1/2 X 3.06	3.62	3/16 x 1.50
252	7.19	.34	11.57	14.47	15.43	5.12	5.250	5.81	N/A	2.91	5/8-11	1.25	7.50	6.07	2.38	9.06	4.78	1/2 x 3.50	3.50	3/16 x 1.75
2600	8.13	1.38	13.30	16.70	18.38	6.50	6.000	6.38	10.24	3.19	5/8-11	1.00	N/A	6.76	2.38	10.00	4.65	5/8 x 4.00	2.78	3/16 x 1.75
2700	7.63	1.57	12.96	16.90	20.46	7.59	7.000	5.50	10.63	2.75	1-8	1.56	N/A	6.76	2.38	11.76	5.65	5/8 x 4.00	4.32	3/16 x 1.75
2800	8.63	1.89	13.94	18.19	23.79	8.86	8.000	6.50	11.93	3.25	1-8	1.66	N/A	9.57	3.47	12.25	5.98	3/4 x 4.50	3.92	1/4 x 2.88
21000	9.53	1.85	17.05	22.30	29.24	10.36	10.000	6.88	14.34	3.44	1 1/4-7	2.04	N/A	10.88	3.38	14.75	6.76	7/8 x 5.00	5.70	1/4 x 3.00

UNIT	T Dia.	U Dia.	V	W	X Dia.	XX	Y	YY	Z Dia.	ZZ
213	.625	.500	.38	5.92	5.00	1.333	4.50	1.72	.34	4.66
215	.750	.500	.38	5.88	5.00	1.333	4.50	1.72	.34	4.66
218	.875	.500	.38	6.64	5.88	1.333	5.00	1.72	.34	4.66
220	1.000	.500	.44	7.88	7.00	1.333	5.99	1.72	.41	4.66
224	1.125	.500	.44	8.39	7.50	1.333	6.27	1.72	.41	4.66
226	1.250	.500	.50	8.88	8.00	1.333	6.67	1.72	.41	4.66
230	1.250	.625	.50	9.89	9.00	1.540	7.37	1.91	.41	5.38
232	1.500	.625	.50	9.89	9.00	1.540	7.37	1.91	.41	5.38
242	1.875	.625	.62	12.95	11.50	2.063	9.65	2.28	.56	6.38
252	2.000	.750	.75	15.50	14.00	2.625	11.75	2.94	.69	8.00
2600	2.500	.875	.75	18.00	15.63	3.250	14.00	3.50	.69	9.38
2700	2.750	.875	.75	21.00	18.38	3.250	15.63	3.50	.78	9.38
2800	3.000	1.250	.75	24.00	21.00	4.250	17.88	4.44	1.03	11.38
21000	3.750	1.250	.75	29.00	25.00	5.250	21.19	5.12	1.03	14.00

*applies to double output shaft
**keyway width by length

Note: All dimensions listed are for reference only. Contact factory for certified dimensions.

WARNING For safety, purchaser or user should provide protective guards over shaft extensions and any couplings, sheaves and belts, sprockets and chains, etc., mounted thereon.

IEC B5 & B3/B5 Metric Motor Flange Face Locations

UNIT	D63D		D71D		D80D		D90D		D100LD D112MD		D132D	
	LQ	RQ	LQ	RQ	LQ	RQ	LQ	RQ	LQ	RQ	LQ	RQ
213	2.62	2.45	2.65	2.47	2.89	2.71	N/A	N/A	N/A	N/A	N/A	N/A
215	2.62	2.45	2.65	2.47	2.89	2.71	N/A	N/A	N/A	N/A	N/A	N/A
218	2.62	2.45	2.65	2.47	2.89	2.71	N/A	N/A	N/A	N/A	N/A	N/A
220	2.62	2.45	2.65	2.47	2.89	2.71	N/A	N/A	N/A	N/A	N/A	N/A
224	2.62	2.45	2.65	2.47	2.89	2.71	N/A	N/A	N/A	N/A	N/A	N/A
226	2.62	2.45	2.65	2.47	2.89	2.71	N/A	N/A	N/A	N/A	N/A	N/A
230	3.15	2.98	3.18	3.00	3.42	3.24	N/A	N/A	N/A	N/A	N/A	N/A
232	3.15	2.98	3.18	3.00	3.42	3.24	N/A	N/A	N/A	N/A	N/A	N/A
242	3.62	3.43	3.65	3.44	3.89	3.68	N/A	N/A	N/A	N/A	N/A	N/A
252	N/A	N/A	4.28	4.09	4.90	4.72	4.90	4.72	5.30	5.07	N/A	N/A
2600	N/A	N/A	4.97	4.78	5.59	5.41	5.59	5.41	5.99	5.76	N/A	N/A
2700	N/A	N/A	4.97	4.78	5.59	5.41	5.59	5.41	5.99	5.76	N/A	N/A
2800	N/A	N/A	N/A	N/A	N/A	N/A	6.38	6.16	6.39	6.14	7.17	6.93
21000	N/A	N/A	N/A	N/A	N/A	N/A	7.78	7.46	7.78	7.45	8.57	8.24

Note: Metric motor flanges are available in quill-style (DFMQ) only.

NEMA Motor Data

NEMA Motor Mounting Dimensions

Frame	AJ	AK	BD	OD	BE	BE1	BORE	KWY.**	BF
48CZ	3.75	3.00	3.88	4.36	.38	N/A	.500	1/8 x 1/16	.28
56C	5.88	4.50	5.88	6.64	.38	N/A	.625	3/16 x 3/32	.41
140TC	5.88	4.50	5.88	6.64	.38	N/A	.875	3/16 x 3/32	.41
180TC	7.25	8.50	9.00	N/A	N/A	.50	1.125	1/4 x 1/8	.53
210TC	7.25	8.50	9.00	N/A	N/A	.50	1.375	5/16 x 5/32	.53
250TC	7.25	8.50	9.00	N/A	N/A	.50	1.625	3/8 x 3/16	.53

**keyway width by depth

NEMA Motor Flange Face Locations

UNIT	48CZ			56C/140TC			180TC			210TC			250TC		
	LM	RQ	LQ	LM	RQ	LQ	LM1	RQ	LQ1	LM1	RQ	LQ1	LM1	RQ	LQ1
213	5.63	3.09	3.46	6.07	3.09	3.46	N/A	N/A	N/A	N/A	N/A	N/A	N/A	N/A	N/A
215	5.63	3.09	3.46	6.07	3.09	3.46	N/A	N/A	N/A	N/A	N/A	N/A	N/A	N/A	N/A
218	5.63	3.09	3.46	6.07	3.09	3.46	N/A	N/A	N/A	N/A	N/A	N/A	N/A	N/A	N/A
220	5.63	3.09	3.46	6.07	3.09	3.46	N/A	N/A	N/A	N/A	N/A	N/A	N/A	N/A	N/A
224	5.63	3.09	3.46	6.07	3.09	3.46	N/A	N/A	N/A	N/A	N/A	N/A	N/A	N/A	N/A
226	5.63	3.09	3.46	6.07	3.09	3.46	N/A	N/A	N/A	N/A	N/A	N/A	N/A	N/A	N/A
230	6.16	3.62	3.99	6.60	3.62	3.99	N/A	N/A	N/A	N/A	N/A	N/A	N/A	N/A	N/A
232	6.16	3.62	3.99	6.60	3.62	3.99	N/A	N/A	N/A	N/A	N/A	N/A	N/A	N/A	N/A
242	6.63	4.06	4.46	7.07	4.06	4.46	N/A	N/A	N/A	N/A	N/A	N/A	N/A	N/A	N/A
252	N/A	N/A	N/A	8.32	4.82	5.19	9.32	5.13	5.62	9.32	N/A	N/A	N/A	N/A	N/A
2600	N/A	N/A	N/A	9.01	5.51	5.88	10.01	5.81	6.31	10.01	6.25	6.75	N/A	N/A	N/A
2700	N/A	N/A	N/A	9.01	5.51	5.88	10.01	5.81	6.31	10.01	6.25	6.75	N/A	N/A	N/A
2800	N/A	N/A	N/A	11.81	6.04	6.45	12.90	6.68	7.21	12.90	6.68	7.21	13.46	7.24	7.77
21000	N/A	N/A	N/A	13.21	7.35	7.85	14.30	7.98	8.61	14.30	7.98	8.61	14.86	8.54	9.17

Metric Motor Data

IEC B5 & B3/B5 Metric Motor Mounting Dimensions

(All dimensions given in millimeters)

Frame	AJ	AK	BD	OD	BE	BORE	KWY.**	BF TAP
D63D	115	95	117	131	10	11	4 x 2	M8 x 1.25
D71D	130	110	132	146	11	14	5 x 2.5	M8 x 1.25
D80D	165	130	165	184	15	19	6 x 3	M10 x 1.50
D90D	165	130	165	184	15	24	8 x 3.5	M10 x 1.50
D100LD*	215	180	216	237	18	28	8 x 3.5	M12 x 1.75
D132D	265	230	267	290	18	38	10 x 4	M12 x 1.75

*also applies to D112MD
**keyway width by depth