

Double Reduction

Helical / Worm Dimensions

Style DX

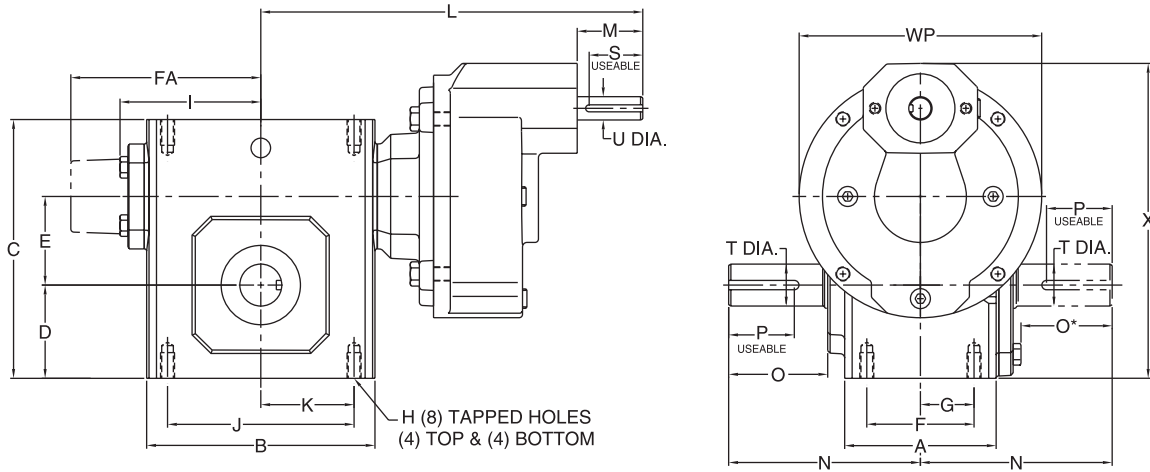

Styles DXMQ & DXM

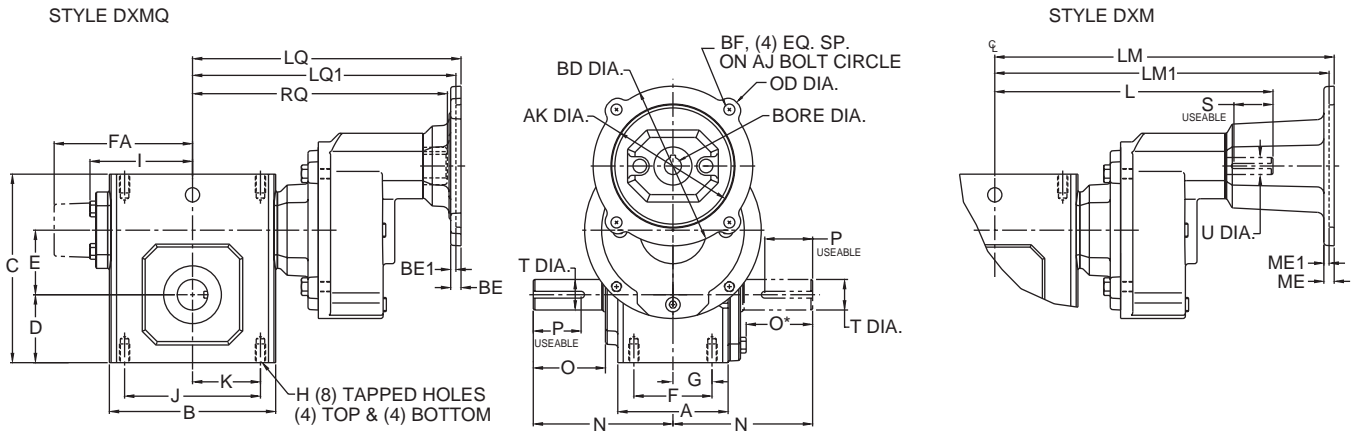

Assemblies

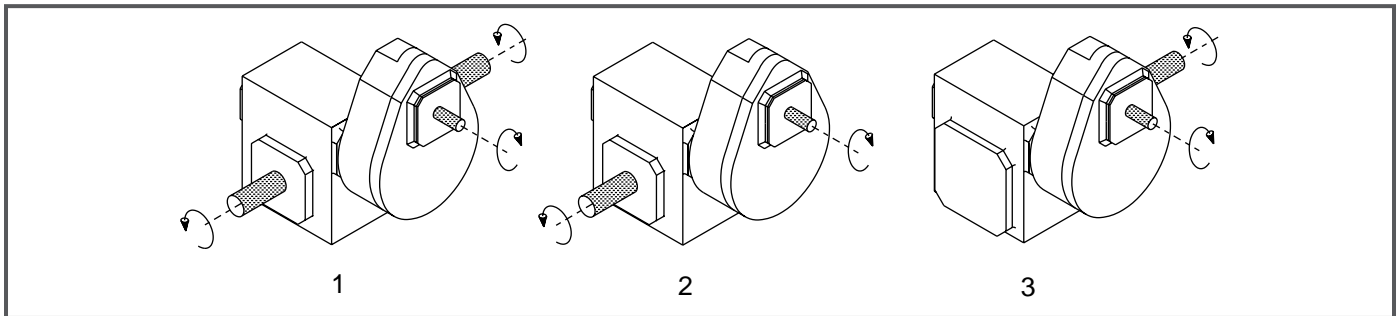

Note: The input shaft may be rotated in either direction. Units are for mounting as shown. Contact factory for other mountings. Assembly positions also apply to motor flange units ("MQ" and "M").



Double Reduction

Styles DX, DXMQ & DXM

UNIT	A	B	C	D	E	F	FA	G	H	H Depth	I	J	K	L	M	N	O	O*
213	2.82	3.80	4.66	1.72	1.333	2.00	N/A	1.00	5/16-18	.50	2.61	3.25	1.63	N/A	N/A	4.00	2.16	1.94
215	3.44	4.88	5.38	1.91	1.540	2.75	N/A	1.38	5/16-18	.63	3.14	4.19	2.09	N/A	N/A	4.31	2.11	1.90
218	3.56	5.06	5.75	2.06	1.750	2.75	N/A	1.38	5/16-18	.63	3.24	4.19	2.09	N/A	N/A	4.31	2.05	1.84
220	3.81	5.80	6.38	2.28	2.063	3.00	N/A	1.50	5/16-18	.63	3.61	4.75	2.38	N/A	N/A	4.68	2.29	2.08
224	4.06	6.12	6.94	2.50	2.375	2.88	N/A	1.44	3/8-16	.69	3.77	5.00	2.50	10.24	1.76	5.14	2.66	2.44
226	4.84	7.12	8.00	2.94	2.625	3.38	N/A	1.69	3/8-16	.69	4.34	6.38	3.19	10.80	1.76	5.63	2.73	2.52
230	5.25	8.12	8.88	3.25	3.000	4.00	N/A	2.00	7/16-14	.88	4.84	7.00	3.50	11.30	1.76	6.75	3.60	3.36
232	5.75	8.50	9.38	3.50	3.250	4.00	N/A	2.00	7/16-14	.88	5.02	7.50	3.75	11.49	1.76	7.06	3.66	3.42
242	6.13	10.25	11.38	4.44	4.250	5.00	N/A	2.50	5/8-11	1.00	6.10	8.50	4.25	17.48	3.61	8.12	4.50	4.21
252	7.19	13.00	14.00	5.12	5.250	5.81	N/A	2.91	5/8-11	1.25	7.50	11.00	5.50	18.88	3.61	9.06	4.78	4.53
2600	8.13	14.25	16.50	6.50	6.000	6.38	10.24	3.19	5/8-11	1.00	N/A	12.75	6.38	19.60	3.61	10.00	4.65	4.65
2700	7.63	14.88	18.91	7.59	7.000	5.50	10.63	2.75	1-8	1.56	N/A	12.50	6.25	19.68	2.50	11.76	5.65	5.65
2800	8.63	17.00	20.96	8.86	8.000	6.50	11.93	3.25	1-8	1.66	N/A	14.25	7.13	21.30	3.00	12.25	5.98	5.98
21000	9.53	20.88	25.47	10.36	10.000	6.88	14.34	3.44	1 1/4-7	2.04	N/A	17.75	8.88	25.78	3.50	14.75	6.76	6.76

UNIT	P**	S**	T Dia.	U Dia.	WP	X
213	3/16 x 1.50	N/A	.625	N/A	5.00	6.16
215	3/16 x 1.50	N/A	.750	N/A	5.00	6.56
218	3/16 x 1.38	N/A	.875	N/A	5.00	6.92
220	1/4 x 1.44	N/A	1.000	N/A	5.00	7.45
224	1/4 x 1.75	3/16 x 1.44	1.125	.625	6.50	8.45
226	1/4 x 2.00	3/16 x 1.44	1.250	.625	6.50	9.13
230	1/4 X 2.25	3/16 x 1.44	1.250	.625	6.50	9.82
232	3/8 X 2.62	3/16 x 1.44	1.500	.625	6.50	10.32
242	1/2 X 3.06	1/4 x 2.17	1.875	1.250	8.50	13.31
252	1/2 x 3.50	1/4 x 2.17	2.000	1.250	8.50	14.99
2600	5/8 x 4.00	1/4 x 2.17	2.500	1.250	8.50	17.12
2700	5/8 x 4.00	1/4 x 2.25	2.750	1.125	10.36	21.84
2800	3/4 x 4.50	5/16 x 2.75	3.000	1.375	11.64	25.93
21000	7/8 x 5.00	3/8 x 3.25	3.750	1.500	13.85	31.35

*applies to double output shaft

**keyway width by length

Note: Sizes 2700 through 21000 have an input shaft which is not aligned with the centerline of the gearbox.

Contact factory for further dimension details.

Note: All dimensions listed are for reference only. Contact factory for certified dimensions.

⚠WARNING For safety, purchaser or user should provide protective guards over shaft extensions and any couplings, sheaves and belts, sprockets and chains, etc., mounted thereon.

NEMA Motor Data

NEMA Motor Flange Face Locations

UNIT	48CZ			56C/140TC			180TC			210TC			250TC		
	LM	RQ	LQ	LM	RQ	LQ	LM1	RQ	LQ1	LM1	RQ	LQ1	LM!	RQ	LQ1
213	N/A	7.79	8.29	N/A	7.79	8.29	N/A	N/A	N/A	N/A	N/A	N/A	N/A	N/A	N/A
215	N/A	8.32	8.82	N/A	8.32	8.82	N/A	N/A	N/A	N/A	N/A	N/A	N/A	N/A	N/A
218	N/A	8.42	8.92	N/A	8.42	8.92	N/A	N/A	N/A	N/A	N/A	N/A	N/A	N/A	N/A
220	N/A	8.79	9.29	N/A	8.79	9.29	N/A	N/A	N/A	N/A	N/A	N/A	N/A	N/A	N/A
224	N/A	N/A	N/A	12.49	9.38	9.88	N/A	N/A	N/A	N/A	N/A	N/A	N/A	N/A	N/A
226	N/A	N/A	N/A	13.05	9.94	10.44	N/A	N/A	N/A	N/A	N/A	N/A	N/A	N/A	N/A
230	N/A	N/A	N/A	13.55	10.44	10.94	N/A	N/A	N/A	N/A	N/A	N/A	N/A	N/A	N/A
232	N/A	N/A	N/A	13.74	10.63	11.13	N/A	N/A	N/A	N/A	N/A	N/A	N/A	N/A	N/A
242	N/A	N/A	N/A	N/A	N/A	N/A	20.66	14.46	14.97	20.66	14.46	14.97	21.22	14.86	15.53
252	N/A	N/A	N/A	N/A	N/A	N/A	22.06	15.86	16.37	22.06	15.86	16.37	22.62	16.26	16.93
2600	N/A	N/A	N/A	N/A	N/A	N/A	22.78	16.58	17.09	22.78	16.58	17.09	23.34	16.98	17.65

NEMA Motor Mounting Dimensions

Frame	AJ	AK	BD	OD	BE	BE1	ME	ME1	BORE	KWY.**	BF
48CZ	3.75	3.00	3.88	4.36	.38	N/A	.38	N/A	.500	1/8 x 1/16	.28
56C	5.88	4.50	5.88	6.64	.38	N/A	.38	N/A	.625	3/16 x 3/32	.41
140TC	5.88	4.50	5.88	6.64	.38	N/A	.38	N/A	.875	3/16 x 3/32	.41
180TC	7.25	8.50	9.00	9.00	N/A	.50	N/A	.50	1.125	1/4 x 1/8	.53
210TC	7.25	8.50	9.00	9.00	N/A	.50	N/A	.50	1.375	5/16 x 5/32	.53
250TC	7.25	8.50	9.00	9.00	N/A	.50	N/A	.50	1.625	3/8 x 3/16	.53

**keyway width by depth