

Double Reduction

Helical / Worm Dimensions

Style DXV(L or H)H

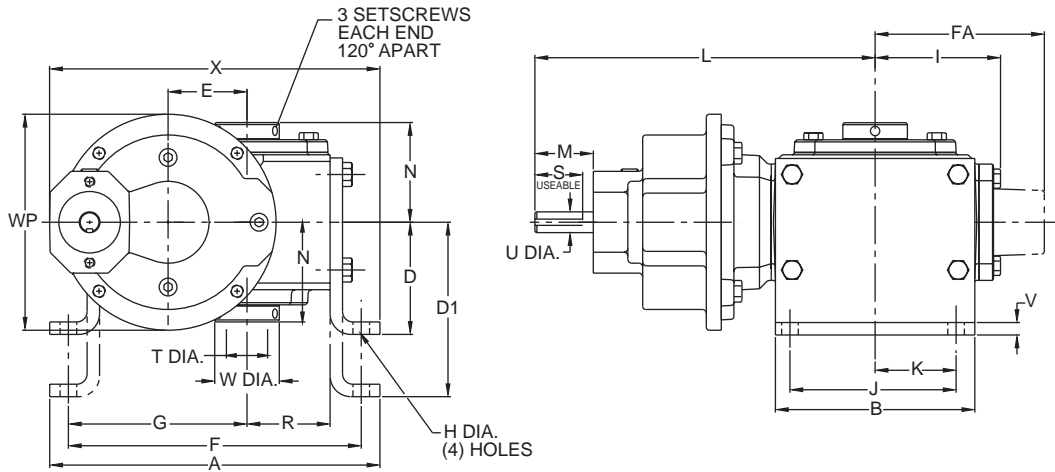

Styles DXV(L or H)HMQ & DXV(L or H)HM

STYLE DXVHMQ

STYLE DXVHM

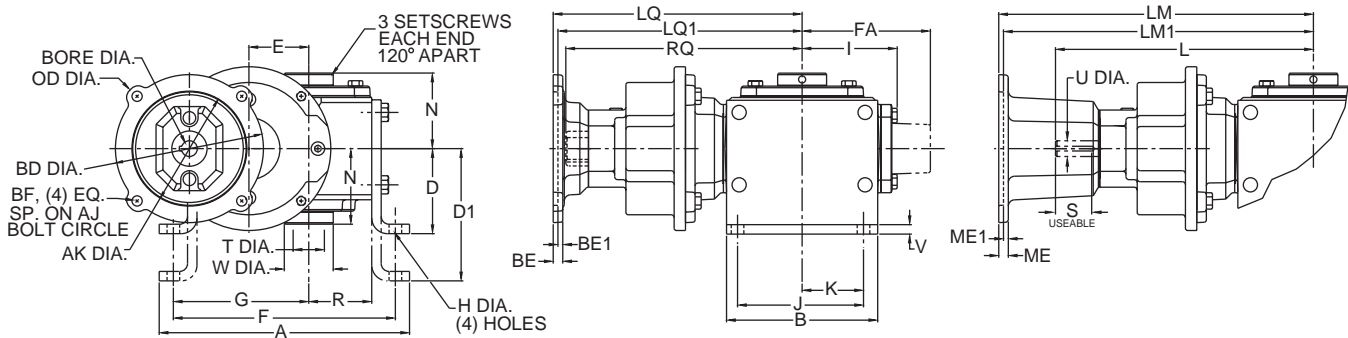

Assemblies

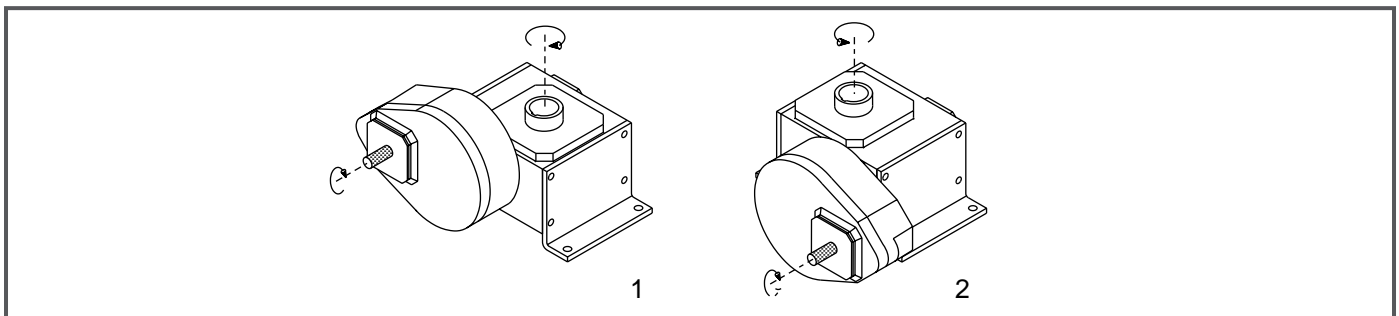

Note: The input shaft may be rotated in either direction. Units are for mounting as shown. Contact factory for other mountings. Assembly positions also apply to motor flange units ("MQ" and "M").

GROVE GEAR

Davis Industries, Inc. Phone & Fax: 800-577-0559 E-mail: sales@davis-ohio.com

Double Reduction

Styles DXV(L or H)H, DXV(L or H)HMQ & DXV(L or H)HM

UNIT	A	B	D	D1	E	F	FA	G	H	I	J	K	L	M	N	R	S**	T-max*
213	7.26	4.00	2.63	3.56	1.333	6.50	N/A	3.86	.38	2.61	3.00	1.50	N/A	N/A	2.38	1.72	N/A	.625
215	7.88	5.00	3.00	4.38	1.540	7.00	N/A	4.28	.44	3.14	4.00	2.00	N/A	N/A	2.71	1.91	N/A	.625
218	8.25	5.00	3.00	4.38	1.750	7.37	N/A	4.50	.44	3.24	4.00	2.00	N/A	N/A	2.75	2.06	N/A	1.000
220	9.38	6.00	3.13	4.88	2.063	8.38	N/A	5.09	.50	3.61	4.88	2.44	N/A	N/A	3.00	2.28	N/A	1.438
224	9.94	6.00	3.38	5.25	2.375	8.81	N/A	5.38	.50	3.77	4.88	2.44	10.24	1.76	3.00	2.50	3/16 x 1.44	1.438
226	11.24	7.00	3.63	5.56	2.625	10.12	N/A	6.12	.56	4.34	5.75	2.88	10.80	1.76	3.50	2.94	3/16 x 1.44	1.438
230	12.50	8.00	3.94	5.88	3.000	11.13	N/A	6.75	.56	4.84	6.00	3.00	11.30	1.76	3.75	3.25	3/16 x 1.44	1.938
232	13.00	8.50	4.69	6.25	3.250	11.88	N/A	7.13	.56	5.02	6.13	3.06	11.49	1.76	3.94	3.50	3/16 x 1.44	1.938
242	16.26	10.00	5.00	7.50	4.250	14.88	N/A	8.69	.69	6.10	7.88	3.94	17.48	3.61	4.25	4.44	1/4 x 2.17	2.188
252	19.62	13.00	5.16	9.16	5.250	18.00	N/A	10.88	.78	7.50	10.00	5.00	18.88	3.61	5.25	5.12	1/4 x 2.17	3.438
2600	23.26	14.75	7.31	9.63	6.000	20.88	10.24	12.19	.91	N/A	11.76	5.88	19.60	3.61	5.75	6.50	1/4 x 2.17	3.438
2700	26.91	14.88	7.00	N/A	7.000	23.99	10.63	13.87	1.13	N/A	12.50	6.25	19.68	2.50	6.75	7.59	1/4 x 2.25	3.938
2800	28.96	17.00	8.00	N/A	8.000	25.50	11.93	14.38	1.13	N/A	14.00	7.00	21.30	3.00	7.25	8.86	5/16 x 2.75	4.438
21000	37.47	20.88	9.00	N/A	10.000	30.75	14.34	17.76	1.44	N/A	17.75	8.88	25.78	3.50	9.25	10.36	3/8 x 3.25	5.438

UNIT	T-kwy***	U Dia.	V	W Dia.	WP	X
213	3/16 x 3/32	N/A	.25	1.00	5.00	7.46
215	3/16 x 3/32	N/A	.25	1.00	5.00	7.81
218	1/4 x 1/8	N/A	.25	1.44	5.00	8.17
220	3/8 x 3/16	N/A	.38	1.94	5.00	8.95
224	3/8 x 3/16	.625	.38	1.94	6.50	9.95
226	3/8 x 3/16	.625	.38	1.94	6.50	10.75
230	1/2 x 1/4	.625	.38	2.51	6.50	11.63
232	1/2 x 1/4	.625	.38	2.51	6.50	12.13
242	1/2 x 1/4	1.250	.50	2.75	8.50	15.75
252	7/8 x 7/16	1.250	.50	4.26	8.50	17.80
2600	7/8 x 7/16	1.250	.50	4.18	8.50	20.50
2700	1 x 1/2	1.125	.75	4.92	10.36	25.84
2800	1 x 1/2	1.375	.75	5.55	11.64	29.93
21000	1-1/4 x 5/8	1.500	1.00	6.67	13.85	37.35

* T dimensions are for max. bore diameter. For other bore diameters refer to catalog page 169.

** keyway width by length

*** keyway width by depth

Note: Sizes 2700 through 21000 have an input shaft which is not aligned with the centerline of the gearbox.

Contact factory for further dimension details.

Note: All dimensions listed are for reference only. Contact factory for certified dimensions.

⚠ WARNING For safety, purchaser or user should provide protective guards over shaft extensions and any couplings, sheaves and belts, sprockets and chains, etc., mounted thereon.

NEMA Motor Data

NEMA Motor Flange Face Locations

UNIT	48CZ			56C/140TC			180TC			210TC			250TC		
	LM	RQ	LQ	LM	RQ	LQ	LM1	RQ	LQ1	LM1	RQ	LQ1	LM1	RQ	LQ1
213	N/A	7.79	8.29	N/A	7.79	8.29	N/A	N/A	N/A	N/A	N/A	N/A	N/A	N/A	N/A
215	N/A	8.32	8.82	N/A	8.32	8.82	N/A	N/A	N/A	N/A	N/A	N/A	N/A	N/A	N/A
218	N/A	8.42	8.92	N/A	8.42	8.92	N/A	N/A	N/A	N/A	N/A	N/A	N/A	N/A	N/A
220	N/A	8.79	9.29	N/A	8.79	9.29	N/A	N/A	N/A	N/A	N/A	N/A	N/A	N/A	N/A
224	N/A	N/A	N/A	12.49	9.38	9.88	N/A	N/A	N/A	N/A	N/A	N/A	N/A	N/A	N/A
226	N/A	N/A	N/A	13.05	9.94	10.44	N/A	N/A	N/A	N/A	N/A	N/A	N/A	N/A	N/A
230	N/A	N/A	N/A	13.55	10.44	10.94	N/A	N/A	N/A	N/A	N/A	N/A	N/A	N/A	N/A
232	N/A	N/A	N/A	13.74	10.63	11.13	N/A	N/A	N/A	N/A	N/A	N/A	N/A	N/A	N/A
242	N/A	N/A	N/A	N/A	N/A	N/A	20.66	14.46	14.97	20.66	14.46	14.97	21.22	14.86	15.53
252	N/A	N/A	N/A	N/A	N/A	N/A	22.06	15.86	16.37	22.06	15.86	16.37	22.62	16.26	16.93
2600	N/A	N/A	N/A	N/A	N/A	N/A	22.78	16.58	17.09	22.78	16.58	17.09	23.34	16.98	17.65

NEMA Motor Mounting Dimensions

Frame	AJ	AK	BD	OD	BE	BE1	ME	ME1	BORE	KWY.**	BF
48CZ	3.75	3.00	3.88	4.36	.38	N/A	.38	N/A	.500	1/8 x 1/16	.28
56C	5.88	4.50	5.88	6.64	.38	N/A	.38	N/A	.625	3/16 x 3/32	.41
140TC	5.88	4.50	5.88	6.64	.38	N/A	.38	N/A	.875	3/16 x 3/32	.41
180TC	7.25	8.50	9.00	9.00	N/A	.50	N/A	.50	1.125	1/4 x 1/8	.53
210TC	7.25	8.50	9.00	9.00	N/A	.50	N/A	.50	1.375	5/16 x 5/32	.53
250TC	7.25	8.50	9.00	9.00	N/A	.50	N/A	.50	1.625	3/8 x 3/16	.53

**keyway width by depth